

Installation Guide for Hengji Solar Photovoltaic Modules

HJM series solar modules are made of 125mm×125mm crystalline solar cells in series with high efficiency, The circuit of cells is laminated using E.V.A (ethylene vinyl acetate) as an encapsulant in a set formed by a tempered glass on its front and a plastic polymer (TEDLAR) on the back which provides resistance against environmental agents and electrical insulation. The laminate is inserted into an anodized aluminium structure. The terminal boxes with IP-65 protection are made using plastics that are resistant to high temperatures and contain the connection terminals and the protection diodes (bypass diodes).The frame has various holes in order to attach the module to the support structure, and to its ground-mounting if necessary.

Figure 1 shows a schematic diagram of a cross-section of a photovoltaic module.

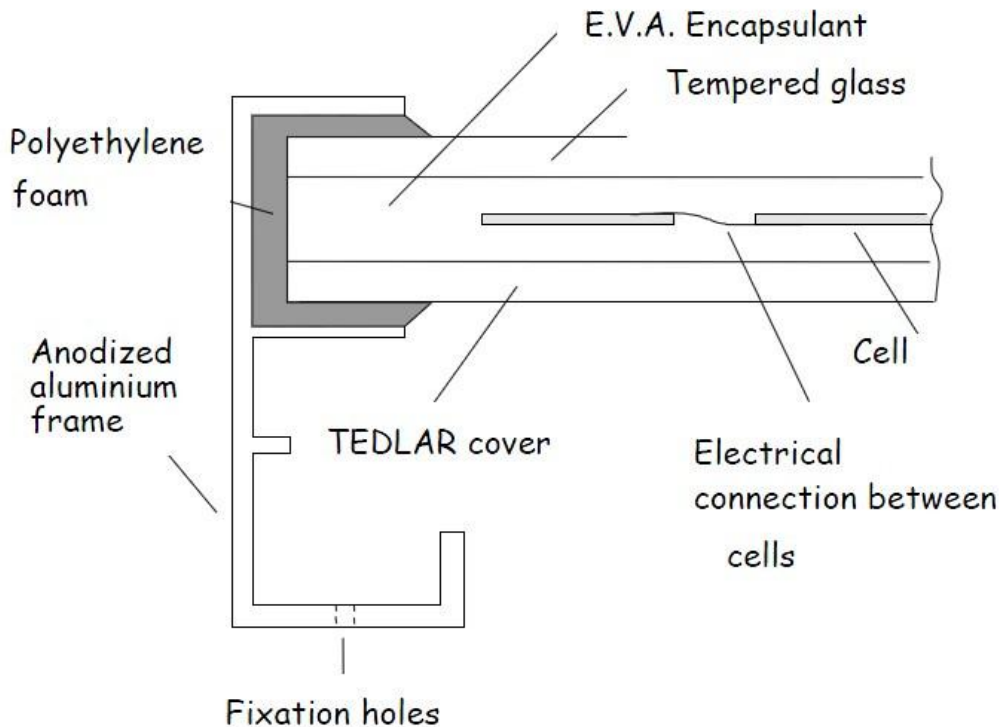

Figure 1 : Cross section of photovoltaic module



authority test center examination. Our products can be used in home proof solar systems, PV stations, communication/communication stations, petrol, ocean, meteorological, traffic and solar building etc.

1、Electrical Specification Mono series

Model Number	Open Circuit Voltage(Voc) <V>	Short Circuit Current(Isc) <A>	Operating Voltage (Vmp) <V>	Current at Rated Operating Voltage (Imp) <A>	Rated Power (Pmax) <W>	Fill factor (%)	Over-current protection rating [A]:>	Application Class (IEC 61730)		
HJM265M-32	60.5	5.66	50.6	5.24	265	77.4	15A	Class A		
HJM260M-32	60.5	5.55	50.6	5.14	260	77.4				
HJM255M-32	60.5	5.44	50.6	5.04	255	77.5				
HJM250M-32	60.5	5.35	50.6	4.94	250	77.2				
HJM245M-32	59.5	5.31	49.8	4.92	245	77.5				
HJM240M-32	58.5	5.30	48.87	4.91	240	77.4				
HJM235M-32	58.4	5.22	48.6	4.84	235	77.1				
HJM230M-32	58.4	5.11	48.6	4.73	230	77.1				
HJM225M-32	58.2	5.04	48.2	4.67	225	76.7				
HJM220M-32	58.2	4.93	48.2	4.56	220	76.7				
HJM215M-32	58.0	4.93	47.1	4.56	215	75.2				
HJM210M-32	58.0	4.82	47.1	4.46	210	75.1				
HJM230M-28	53.2	5.58	44.5	5.17	230	77.5			15A	
HJM225M-28	53.2	5.46	44.5	5.06	225	77.5				
HJM220M-28	53.2	5.35	44.5	4.94	220	77.3				
HJM215M-28	52.8	5.25	44.2	4.86	215	77.6				
HJM210M-28	52.8	5.13	44.2	4.75	210	77.5				
HJM205M-28	52.1	5.08	43.6	4.70	205	77.5				
HJM200M-28	52.1	4.95	43.6	4.59	200	77.6				
HJM195M-28	51.6	4.87	43.2	4.51	195	77.6				
HJM190M-28	51.6	4.75	43.2	4.40	190	77.5	15A			
HJM100M-12	23.10	5.69	18.98	5.27	100	76.1				
HJM95M-12	22.37	5.58	18.38	5.16	95	76.1				
HJM90M-12	21.98	5.37	18.06	4.98	90	76.3				
HJM85M-12	21.98	5.07	18.06	4.70	85	76.3				
HJM80M-12	21.86	4.89	17.68	4.53	80	74.8				

- Modules rated for use in this application class may be used in systems operating at greater than 50V DC or 240W, where general contact access is anticipated. Modules qualified for safety through IEC 61730-1 and this part of IEC 61730 within this application class are considered to meet the requirements for safety class II.
- We recommend the maximum number of modules in parallel should be no more than 3, while the maximum number of modules in series no more than 22.
- The electrical characteristics are within ± 3 percent of the indicated values of Isc, Voc and Pmax under standard test conditions (irradiance of 100 mW/cm², AM1.5 spectrum, and a cell temperature of 25°C).



- Under normal conditions, a Photovoltaic module is likely to experience conditions that produce more current and/or voltage than reported at standard test conditions. Accordingly, the values of Isc and Voc marked on this module should be multiplied by a factor of 1.25 when determining component voltage ratings, conductor ampacities, fuse sizes, and size of controls connected to the PV output.
- Refer to section 690-8 of the NEC for an additional multiplying factor of 125 percent (80 percent derating) which may be applicable.
- Safety Standard for Electrical Installations, please refer to national building codes and safety requirements.

No	Item	Manufacturer	model	Remark
1	Dimensions	Jiang Yin Haida	Anodized Aluminum frame 6063 T5	1580mm *1062mm *50mm 1834mm *808mm *50mm 1200mm *540mm *50mm
2	Weight			20.0Kg、 17.5 Kg、 8.5 Kg
3	Cell	JingAo solar	JA125S	96 pcs (125mmx125mm) solar cells, 8 lines12 rows connected in series and array in matrix. 84 pcs (125mmx125mm) solar cells, 6 lines14 rows connected in series and array in matrix. 36 pcs (125mmx125mm) solar cells, 4 lines 9 rows connected in series and array in matrix.
4	Output cable	CiXi Renhe Photovoltaic Electrical Appliance Co.,Ltd	PV1-F	4mm ² cable with TUV certification, with polarity mark, waterproof, length is 900mm。
5	Bypass diode	Yangzhou Yangjie Electronic Technology Co., Ltd.	10SQ050	4 pairs; every pair contain 2 diodes in parallel 3 pairs; every pair contain 2 diodes in parallel 2 pairs; every pair contain 2 diodes in parallel
6	Junction box	CiXi Renhe Photovoltaic Electrical Appliance Co.,Ltd	PV-RH0502B-4 PV-RH0502B-3 PV-RH0502B-2	With 4 pcs connector, IP65, max system voltage 1000VDC, max current 10A ,outer material is PPO and with TUV certification
7	Structure			Front: high transparence toughened glass Front: high transmission toughened glasses with 3.2 mm (1/8inch) height Back: Polyester Material : EVA:
8	Frame			Anode oxidation. Aluminum alloy frame 6063T5 Color: Silver
9	Insulated performa			50M

	nce			
10	Max system voltage			DC 1000V

3、Structure

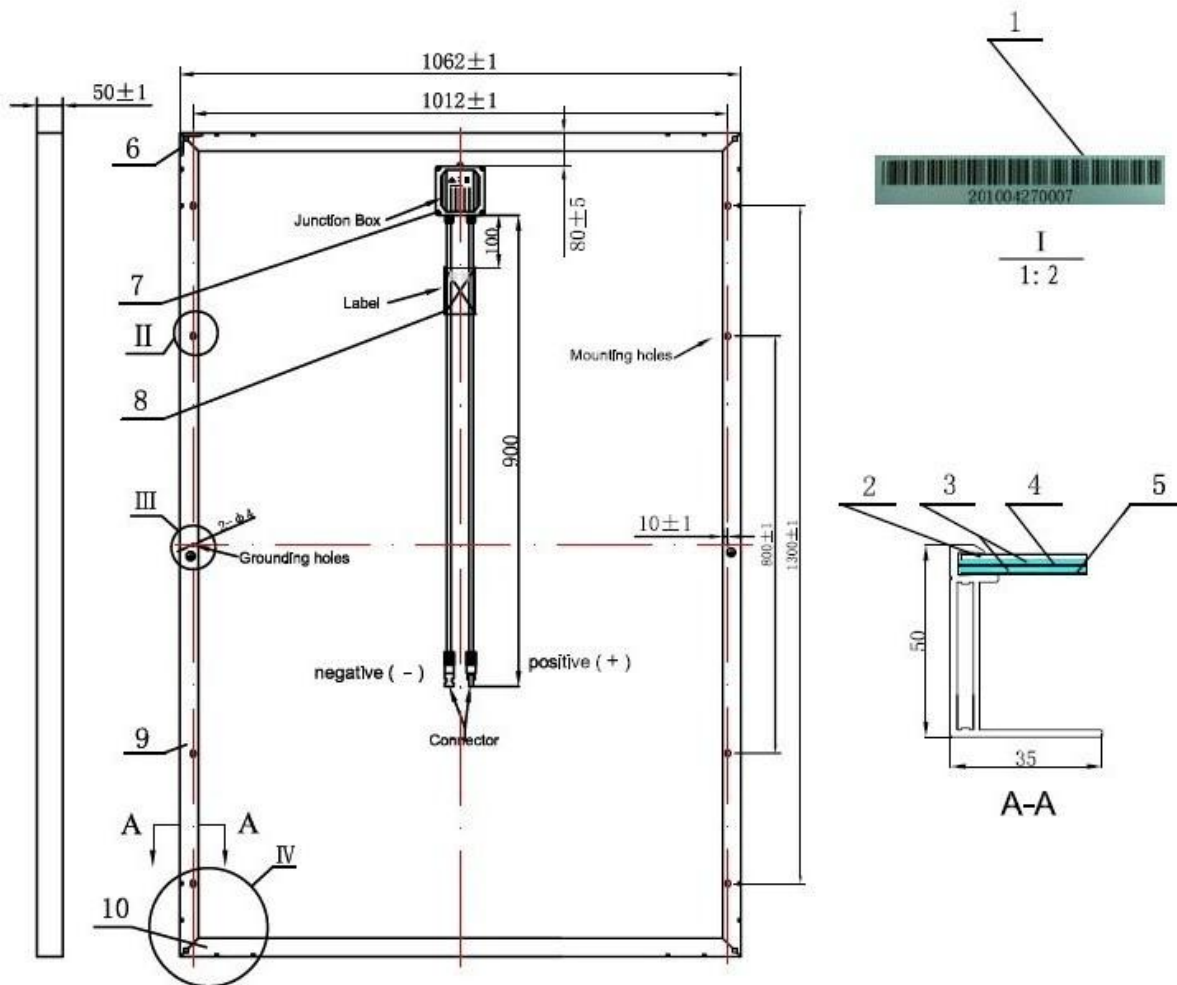

4、Operating environment

CLIMATE CONDITION

Install the PV module in the following conditions:

Environment temperature: -20°C to 40°C .

Operating temperature: -40°C to 80°C .

Waterproof: don't put the modules dip in the water or continually explode under the water device or fountain.

Antisepsis: except salt erode and sulfuration places.

5、 Mounting and notes

The modules electrical performances in a system are the same. When connected in series, all modules must have the same amperage. When connected in parallel, the modules must all have the same voltage. Connect the quantity of modules that match the voltage specifications of the devices used in the system. The modules must not be connected together to create a voltage, a voltage higher than the permitted system voltage.

To minimize risk in the event of an indirect lightning strike avoid forming loops when designing the system.

Modules must not be fitted as overhead glazing. Ensure that the mounting system can also withstand the anticipated wind and snow loads.

Precipitation can run off through small openings on the back side of the module. Make sure that the openings are not masked after mounting.

The maximum load on the module must not exceed 2.4kN/m². To avoid exceeding the maximum load, site-specific live loads such as wind and snow should take into account.

The installation of project must be facing the north in the south hemisphere, and facing south in north hemisphere, it will be comparatively lower electricity when the project facing the west or east. The incorrect installation will lead to the losing of the power

The modules, which connected in series, must be in same angle, otherwise, it will lose the power because of the differences of sunshine radiation.

Solar modules produce the most power when they are pointed directly at the sun. For installations where the solar modules are mounted to a permanent structure, the solar modules should be tilted for optimum winter performance. As a rule, if the system power production is adequate in the winter, it will be satisfactory during the rest of the year. The module tilt angle is measured between the solar modules and the ground.

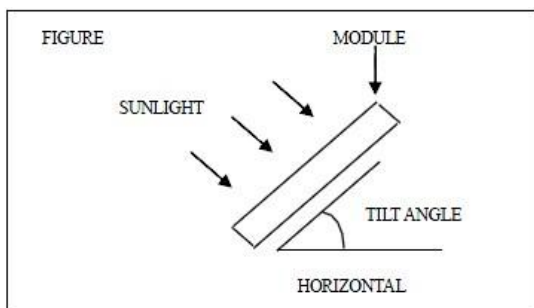

RECOMMENDED TILT ANGLES FOR A FIXED SYSTEM	
SITE LATITUDE IN DEGREES	FIXED TILT ANGLE
0° TO 15°	15°
15° TO 25°	SAME AS LATITUDE
25° TO 30°	LATITUDE+5°
30° TO 35°	LATITUDE+10°
35° TO 40°	LATITUDE+15°
40° +	LATITUDE+20°

Must Avoid installing under the shadow, even the module factory use the bypass diode to decrease the lose of energy, but the shadow will lead to losing of output power.

Suitable installation

Make sure the module meets the technical requirements of the system as a whole. Ensure that other



system components do not exert damaging mechanical or electrical influences on the modules. When connected in series, modules must all have the same amperage. When connected in parallel, the modules must all have the same voltage. The modules must not be connected together to create a voltage higher than the permitted system voltage. We recommend that the maximum number of modules in parallel should be no more than 3 while the maximum number of modules in series no more than 20. Modules must not be fitted as overhead glazing or vertical glazing. Ensure that the mounting system can also withstand the anticipated wind and snow loads. There are openings at the base of the module frame to allow water from precipitation to drain. Ensure that these openings are not blocked nor partially blocked by the module installation method.

Artificially concentrated sunlight shall not be directed on the module or panel.

6、Grounding

The grounding clip accepts solid uninsulated copper wire sizes 10 or 12AWG. The wire must not be nicked, cut, or scraped. There is no preparation required.

Attach a separate conductor to one of the 4mm diameter grounding holes marked 'GR' on the module frame with a bolt and nut that incorporates an external tooth washer. This is to ensure positive electrical contact with the frame.

Although the modules are certified to safety class II, we still recommend earthing them. A qualified electrician must make the earth connection.

Option 1: Connect module frames to each other using cables with cable lugs. Use the hole (4.0mm) that are provided for this purpose. To create the conductive connection (frame is anodized), use a serrated washer or a self-tapping screw (5mm). A qualified electrician should make the earth connection.

Option 2: Create an electrical connection between the frames and the mounting system, e.g. by using serrated washer, then have the mounting system earthed by a qualified electrician.

Do not interrupt or influence the conductive connection when making daily maintenance.

All the crunodes on the conductive connection must be fixed. The fastness does not depend on soldering.

The metal containing iron in the conductive connection should be handled by some way, such as anodization, spray-painting, galvanization. Stainless steel does not need to

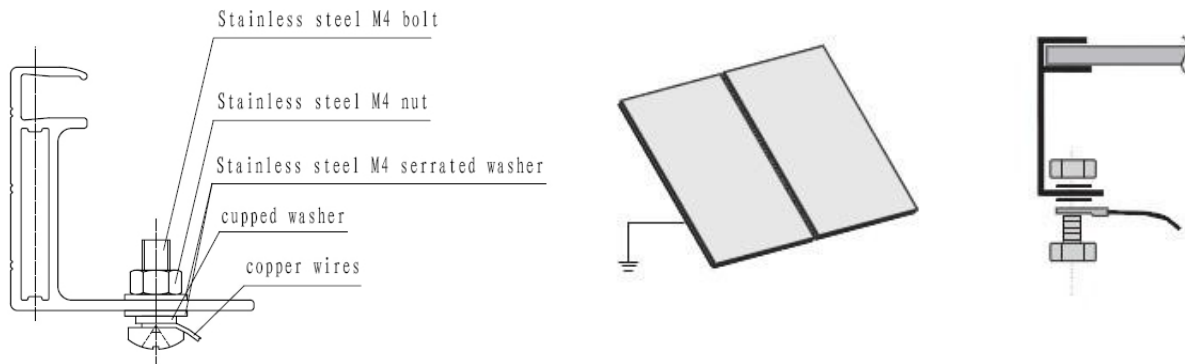

Use the holes(4.0mm) marked '  '. To create the conductive connection (frame is anodized), use Stainless steel M4 nut, two Stainless steel serrated washer and Stainless steel M4 bolt.

1. Copper wires with M4 cupped washer should be placed through the bolt;
2. Put the serrated washer through the bolt, and the bolt must be put through the hole fixed in the aluminum frame;
3. Use the nut and serrated washer to fix all the parts. The copper wire can not be attached to the aluminum.

Do not interrupt or influence the conductive connection when making daily maintenance .All the crunodes on the conductive connection must be fixed. The fastness does not depend on soldering.

7、 Suggested maximum number of modules in parallel and in series

When designing the system, we recommend that the maximum number of modules in parallel should be no more than four while the maximum number of modules in series no more than eight.

8、 Mounting

Each module must be securely fastened at a minimum of 6 points(14mm×9mm). The frame has been stress tested for mounting on the long sides. Its short sides must not secure the module.

We recommend using a torque wrench for installation. the tightening torque(using stainless steel M8 bolts、 Stainless steel washer and Stainless steel M8 nut) should be around 15-20Nm.Use the existing holes for securing the module and do not drill additional holes(doen so would void the warranty).Use appropriate corrosion-proof fastening materials.

Clearance between the module frame and mounting surface may be required to prevent the junction box from touching the surface, and to circulate cooling air around the back of the module. If the modules are to be installed on the roof or wall of a building, the standoff method or the rack method is recommended.

Stand-off method: The modules are supported parallel to surface of the building wall or roof. Clearance between the module frames and surface the wall or roof is required to prevent wiring damage and to allow air to circulate behind the module.

The recommended stand-off height is 115mm. If other mounting means are employed, this may affect the Listing For Fire Class Ratings.

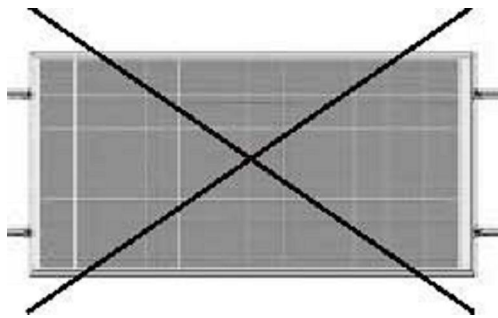

Do not mount on the short side

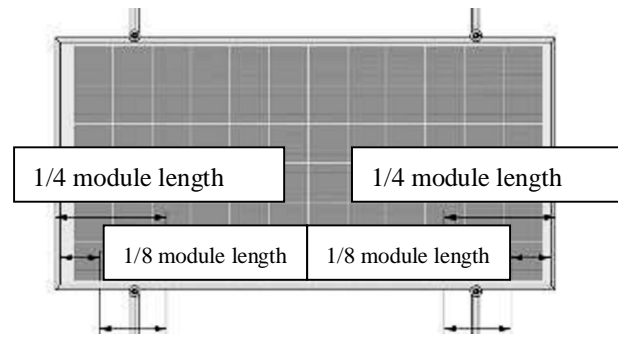

mounting area

mounting area

PV modules can be mounted to the substructure by clamping on (Example A) at the front side or by screwing (Example B) at the back side.

Example A: Clamping

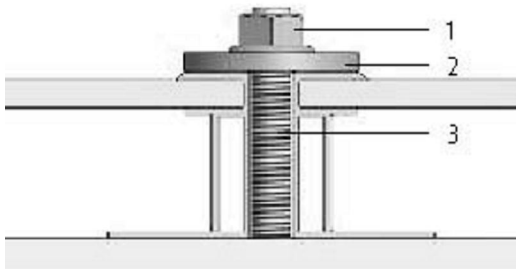

Example B: Bolting

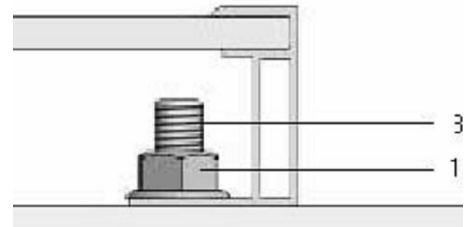

- 1) Stainless steel serrated lock nut
- 2) Stainless steel washer
- 3) Stainless steel M8 (5/16 inch) T-head bolt

The clamping area (Example A) of the washer must cover at least 135 mm² or 0.21 in². A torque wrench must be used for assembly. In the examples shown, the tightening torque (using stainless steel M8 or 5/16 inch bolts) must be 16 Nm or 11.8 ft-lbf. Use the existing holes for securing the module; do not drill any additional holes (doing so would void the warranty). Use appropriate corrosion proof fastening materials.

9、Wiring

For the wiring, pay attention to:

HJM180M-24 use the RENHE PV-RH0502B junction box. This box, on the back side of the module, is weatherproof and is designed to be used with standard wiring or conduit connections. Wiring methods should be in accordance to the NEC

(National Electrical Code). Bypass diodes and cable clamps are included with each module when shipped from the factory.

Correct wiring scheme

Industry Area Lianshi Town, Huzhou, Zhejiang Province, 313013, P.R.China
TEL: +86 572 3561661 FAX: +86 572 3561662 Web: www.hjsolarpv.com

When designing the system, avoid forming loops (to minimize risk in the event of an indirect lighting strike). Check that wiring is correct before starting up the generator. If the measured open circuit voltage (U_{oc}) and short-circuit current (I_{sc}) differ from the specifications, then there is a wiring fault.

Correct connection of contact plug connectors

The plug connector has its own polarity. Make sure that the connection is safe and tight. The plug connector should not receive outer stress. Otherwise, it is only used to connect the circuit!

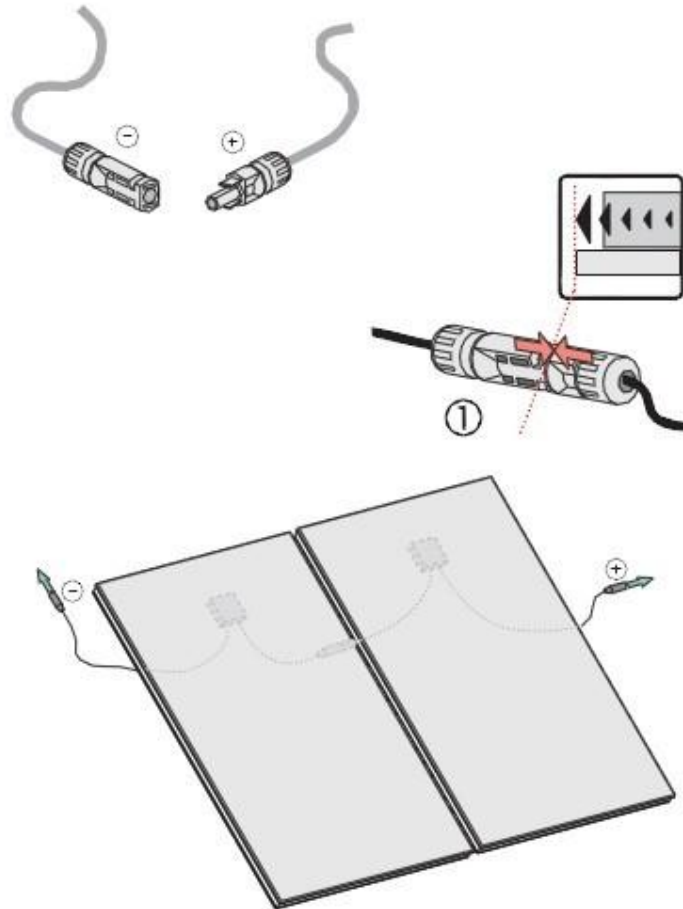

Use of suitable materials

Use cable extensions and plugs that are designed for outdoor applications. Ensure that they are in perfect electrical and mechanical condition. Use only cables having one conductor. Select the appropriate cable diameter to minimize voltage drop (to calculate the minimum cable diameter, the fuse, and to calculate controls, multiply the I_{sc} and U_{oc} by a factor of 1.25).

If module connect the control box, you must choice the box with Connectors RENHE 05-1 or MC-T4

10、 Bypass diodes

Partial shading of an individual module can cause a reverse voltage across the shaded module. Current is then forced through the shaded area by the other modules.

When a bypass diode is wired in parallel with the series string, the forced current will flow through the



diode and bypass the shaded module, thereby minimizing module heating and array current losses.

Diodes that are used as bypass diodes must:

Have a Rated Average Forward Current 10A above maximum system current at highest module operating temperature.

Have a Rated Repetitive Peak Reverse Voltage 50V above maximum system voltage at lowest module operating temperature.

11、 Battery

When solar modules are used to charge batteries, the battery must be installed in a manner which will protect the performance of the system and the safety of its users. The battery should be away from the main flow of people and animal traffic. Select a battery site that is protected from sunlight, rain, snow, debris, and is well ventilated. Most batteries generate hydrogen gas when charging, which is explosive. Do not light matches or create sparks near the battery bank. When a battery is installed outdoors, it should be placed in an insulated and ventilated battery case specifically designed for the purpose.

12、 Maintenance and cleaning

Do not change the PV components optionally (diode, junction box, plug connectors)

Given a sufficient tilt (at least 15°), it is not generally necessary to clean the modules (rainfall will have a self-cleaning effect). In case of heavy soiling (which will result in output reductions), we recommend cleaning the modules using plenty of water (from a hose) without cleaning agents and using a gentle cleaning implement (a sponge). Dirt must never be scraped or rubbed away when dry, as this will cause micro-scratched. We recommend that the system be inspected at regular intervals.

All fastenings are tight and secure and free of corrosion.

All cable connections are secure, tight, clean and free of corrosion.

Cables are not damaged in any way.

Checking the earthing resistivity of metals.

Danger of death from electric shock!

Solar modules generate electricity as soon as they are exposed to light. One module on its own is below the safety extra low volt level, but multiple modules connected in series (summing the voltage) or in parallel (summing the current) represent a danger. The following points must be observed when handling the solar modules to avoid the risk of fire, sparking and fatal electric shock.

Do not insert electrically conducting parts into the plugs or sockets!

Do not fit solar modules and wiring with wet plugs and sockets!

Exercise utmost caution when carrying out work on wiring and safety equipment (use insulated tools, insulated gloves, etc.)!

Do not use damaged modules! Do not dismantle modules! Do not mark on the rear of the module using sharp objects!

Exercise utmost caution when working on wiring and the inverter. Be sure carefully to follow manufacture's installation instructions!

Danger of death from arcing !

Modules generate direct current when light shines on them. An arc may be produced when connections are separated. We therefore recommended covering modules with a lightproof cloth during installation.

When breaking a connected string of modules (e.g. when disconnecting the DC line from the inverter under load), a lethally strong arc can occur:

Never disconnect the solar generator from the inverter while the inverter is connected to the mains grid—remove the fuse from the AC side on the inverter first!

Ensure cable connections in perfect condition (no splitting, soiling or other contamination)!

Remark: all size are based in mm unit, and the tolerance is +/- 2 mm

14、Storage and transportation

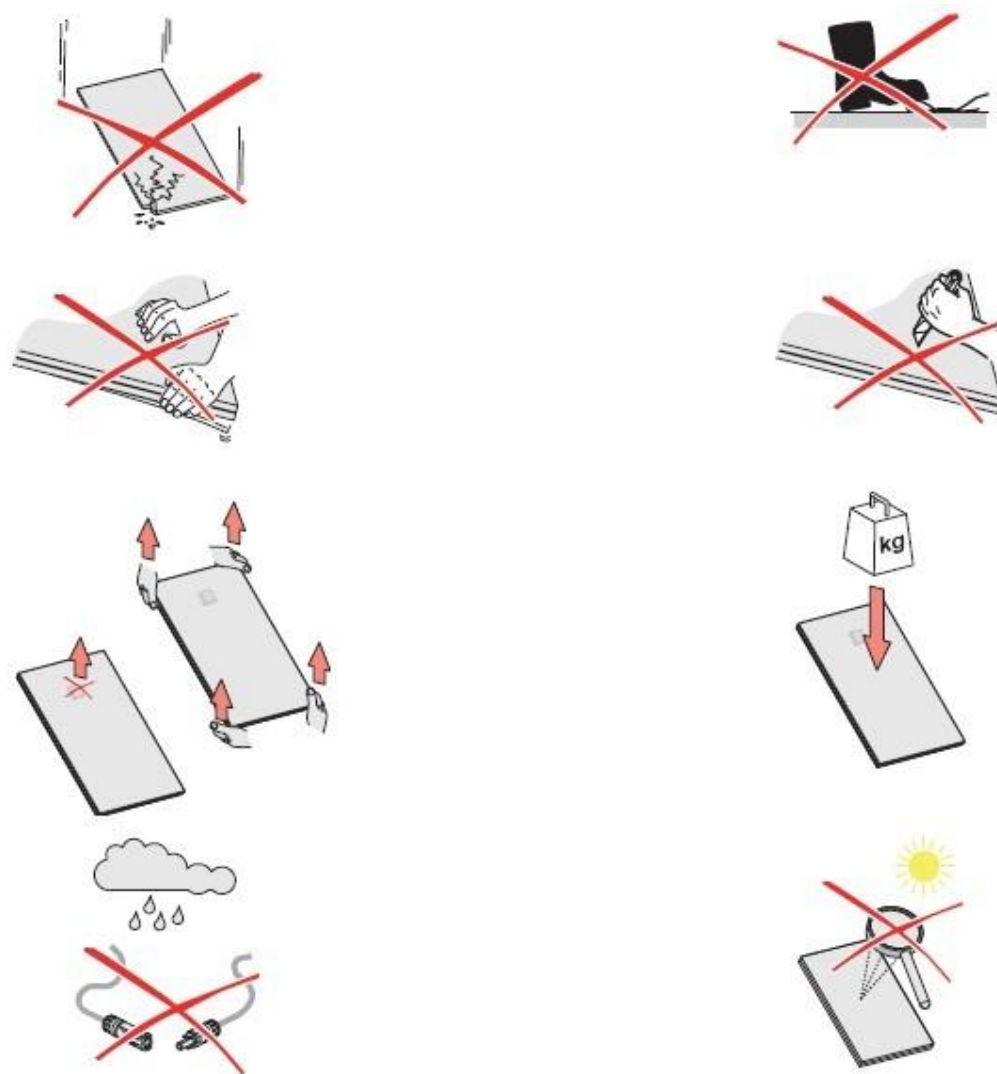

ZHEJIANG HENGJI PV-TECH ENERGY CO.,LTD

Add:Industry Area lianshi Town, Huzhou,Zhejiang

Industry Area Lianshi Town, Huzhou, Zhejiang Province, 313013, P.R.China

TEL:+86 572 3561661 FAX:+86 572 3561662Web:www.hjsolarpv.com



浙江恒基光伏电力科技股份有限公司
ZHEJIANG HENGJI PV-TECH ENERGY CO.,LTD.

Province,313013,China
Phone: +86-572-2688289
Fax: +86-572-3560998
Web: www.hjsolarpv.com